



MIBRASA HMB AB-SB 75, 110, 160

Mibrasa charcoal oven with cupboard below and heating rack

TECHNICAL INFORMATION	HMB MINI	HMB 75	HMB 110	HMB 160
Diners*	35	75	110	160
Fire up time* (min)	20	25	30	35
Cooking temperature (°C)	250-350	250-350	250-350	250-350
Charcoal consumption* (kg/day)	7	13	18	20
Production* (kg/h)	25	70	100	120
Performance* (h)	8	9	10	10
Useful dimensions of grill (mm)	500 x 350	500 x 600	720 x 600	720 x 800
Equivalent power* (kW)	2	3,5	5	6
Exhaust rate (m ³ /h)	1500	2000	2400	2600

* Approximate data

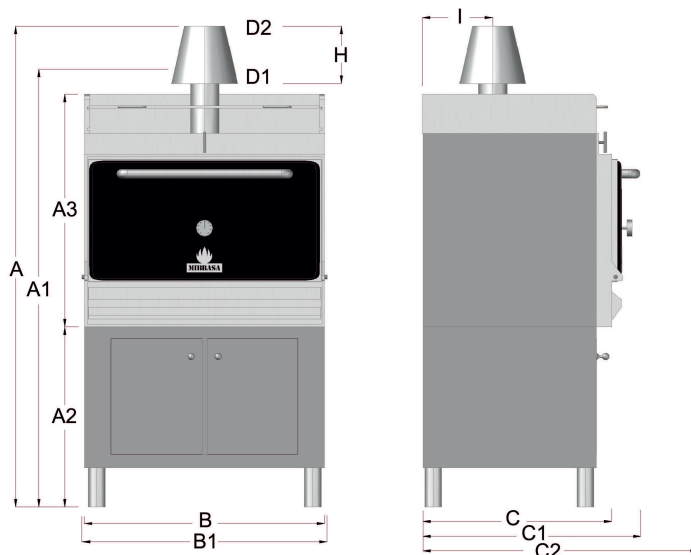

INCLUDED ACCESSORIES

- Grill
- Oven tongs
- Charcoal ember pocker
- Ash shovel
- Grill brush

OPTIONAL ACCESSORIES

- Extra grill
- Firebreak
- Dissipating filter
- Cookware
- Steel wheels with brakes

Model	A	A1	A2	A3	B	B1	C	C1	C2	H	I	D1	D2
HMB AB SB 75	1810	1630	740	800	700	730	640	820	1080	230	300	115	150
HMB AB SB 110	1860	1680	690	890	920	950	640	820	1170	230	300	115	150
HMB AB SB 160	1860	1680	690	890	920	950	840	1020	1360	230	350	115	150

OVEN'S DESCRIPTION

The air inlet is controlled by opening or closing the ash collector.



1. Firebreak
2. Regulator
3. Door handle
4. Grills
5. Thermometer
6. Interior grills
7. Door
8. Grease collector
9. Ash collector